

## PROCESS SYSTEM CUTS HARDWARE COST BY 25%

A food manufacturer discovers that the right I/O hardware solution for its controls system can create significant cost savings.

By Richard Phillips, Project Manager, Polytron, Inc.

**>>** Reducing cost is always one of the top priorities for every automation integration project. Combine this with the economic downturn limiting capital investments, and it becomes even more crucial for system integrators to deliver the promised project results at the lowest possible cost. However, how can you achieve cost reduction without sacrificing

### >> How to Determine I/O Types

Polytron analyzed three I/O types deemed most suitable for the food manufacturer's project: Rack I/O, Flex I/O and Point I/O. Project teams should carefully analyze all of the project's requirements to determine the appropriate I/O type for a project. Here are some general rules of thumb:

- **Rack I/O** is optimal when all I/O points are near one panel or a small group of panels, or when specialty cards are required.
- **Flex I/O** typically is best for I/O clusters spread throughout various locations in the plant.
- **Point I/O** most often is selected when individual I/O points are spread throughout the plant.

the project's requirements? Let's examine one project and learn how a food manufacturer teamed with Polytron, Inc., a Rockwell Automation qualified Process Solution Provider, to save money while improving control system performance.

The new process system for the manufacturer's state-of-the-art greenfield facility included roughly 6,000 I/O points comprised of digital, analog and DeviceNet I/O. Our company provided controls automation and manufacturing execution system (MES) design services for multiple process and packaging lines.

We analyzed the manufacturer's planned I/O hardware design to ensure it provided the best value for the project. This analysis led us to recommend a new design that resulted in an approximate 25% cost savings for the controls hardware.

As the system's mechanical design evolved, additional I/O had to be added to support the increased processing capabilities requested by the manufacturer. This increased the I/O by more than 20%, from 6,000 I/O points to more than 7,000. This increase of scope typically creates budget issues for a project.

### >> How to Determine Network Types

Polytron considered three network types for this automation integration project: ControlNet, DeviceNet and Ethernet. Here are some general rules of thumb:

- **ControlNet** typically is preferred when truly deterministic I/O is required, such as for servo motion or in a redundant CLX system.
- **DeviceNet** is used mostly for communicating to DeviceNet-enabled devices, and allows transmission of significantly more information than digital and analog interfaces.
- **Ethernet** typically is more readily available, lower cost and quickly becoming the preferred networking option.

However, the new design allowed the additional scope to be delivered at a 10% cost savings of the original controls hardware budget. Here's how.

### The Technical Approach

The originally planned control system consisted of connecting

eight Allen-Bradley® ControlLogix® programmable automation controllers (PAC) from Rockwell Automation to Remote I/O racks via ControlNet (see **Figure 1**). At the start of the detailed design phase, we analyzed the planned design and customer requirements. This analysis included use of the Rockwell Automation Integrated Architecture Builder (IAB) software ([www.rockwellautomation.com/go/iab](http://www.rockwellautomation.com/go/iab)) and EtherNet/IP Capacity Tool ([www.rockwellautomation.com/go/iatools3](http://www.rockwellautomation.com/go/iatools3)).

The EtherNet/IP Capacity Tool allowed the systems integrator to determine the network layout and connection media most suitable for the project.

The IAB provided a Bill of Material based on design information entered into the IAB software, such as I/O type, number of nodes, I/O points connected to each node and network type. This, in turn, allowed pricing to be obtained for each design option. We developed “what if” scenarios to determine the cost for each configuration option.

We then used the EtherNet/IP Capacity Tool to determine the predicted performance for each EtherNet/IP network option.

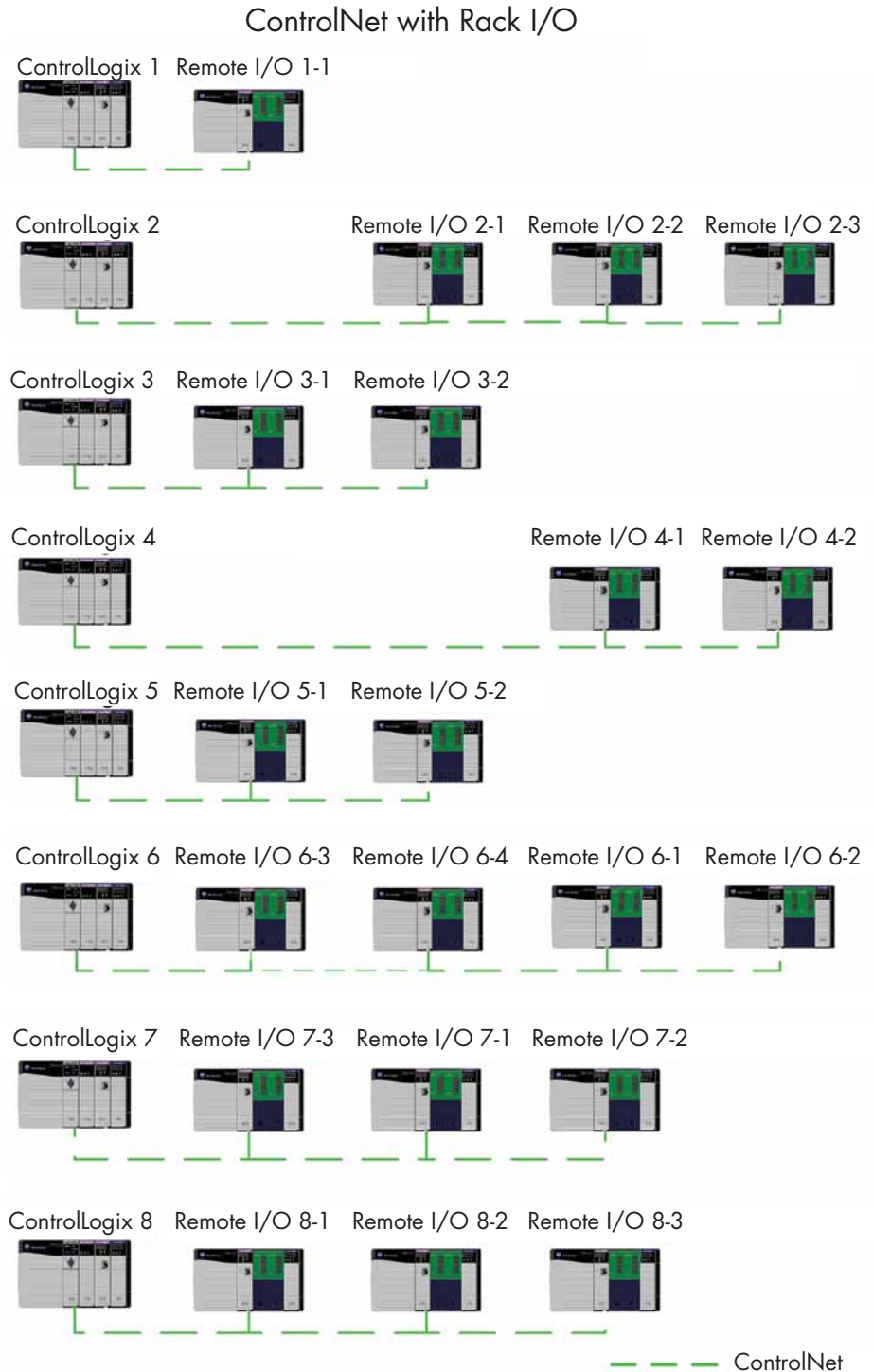

**Figure 1.** The control system originally planned for the food manufacturer consisted of connecting eight Allen-Bradley ControlLogix PACs to Remote I/O racks via ControlNet. The systems integrator analyzed the design and customer requirements using the Rockwell Automation Integrated Architecture Builder (IAB) software and EtherNet/IP Capacity Tool.

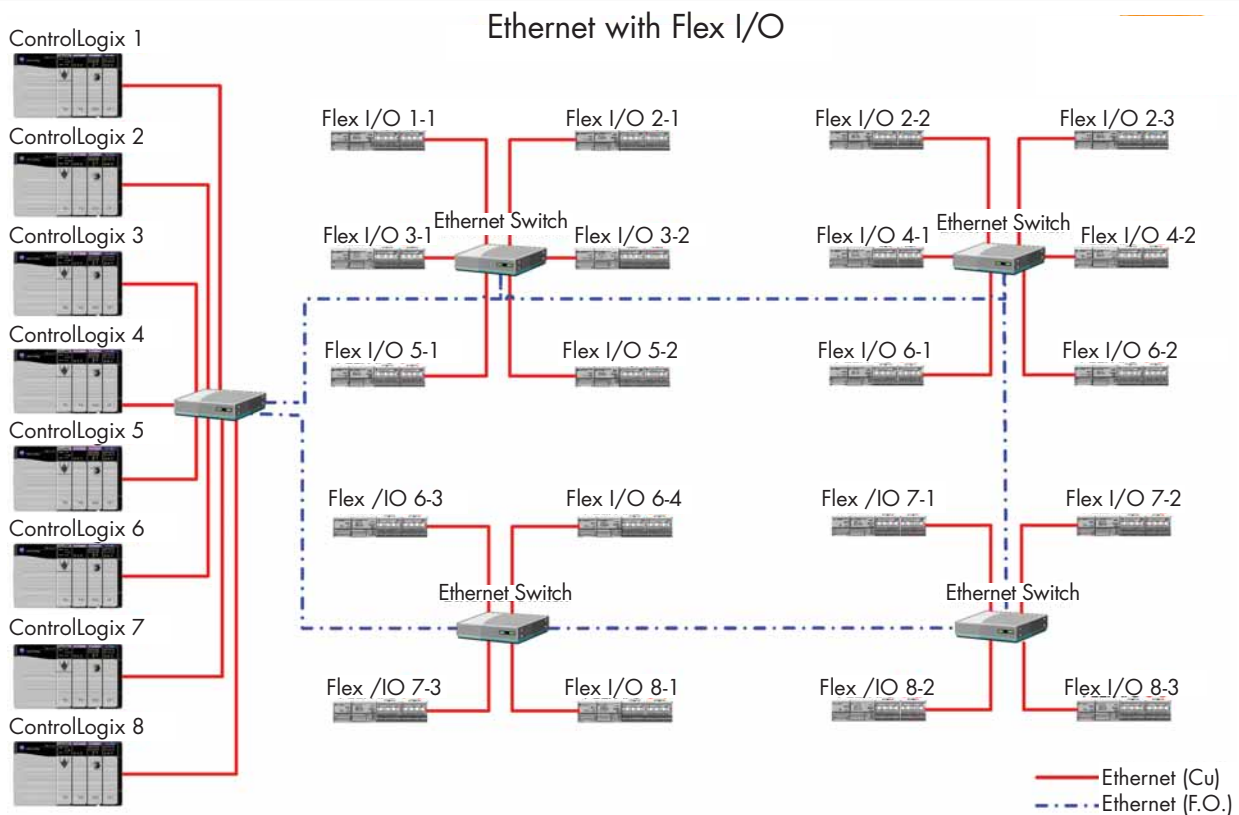

**Figure 2.** The project team changed the design to an Ethernet with Allen-Bradley Flex I/O. As a result, the manufacturer saved 25% on controls hardware, reduced network types in the plant and achieved smaller panel footprints.

## >> SOLUTION PROVIDERS

A select group of Rockwell Automation system integrators has achieved Solution Provider partnership status. This is a heightened and exclusive business relationship with Rockwell Automation. Solution Provider partners are proven, trusted and established organizations that offer extensive experience in the design, implementation, project management and maintenance of customers' industrial control systems.

**Discipline:** To earn Solution Provider (SP) partner status, integrators must possess high corporate standards, financial stability, proven methodologies and competency using Rockwell Automation technologies.

**Credibility:** SPs are well-established organizations that offer extensive experience in advanced automation solutions. They have been trusted advisers for their customers from initial design and consultation, system development, through the commissioning of comprehensive Rockwell Automation solutions.

**Expertise:** Whether your need is in design, project management, implementation or manufacturing systems maintenance,



SPs possess the industry knowledge, domain expertise, resources and skills to deliver world-class solutions.

Rockwell Automation recently expanded its Process Systems Integrator Program in 2009 with 45 new members. With expertise in the metals, power generation and other process industries, the new program members will support the Rockwell Automation PlantPAX™ Process Automation System, bringing plant-wide control on a single platform to manufacturers looking to migrate their aging DCS systems. New program members also include 18 Latin American Solution Provider partners.

These process system integrators are reviewed for domain expertise, engineering excellence and geographic reach, among other criteria.

They're selected for their abilities to help Rockwell Automation deliver value through the design, development and delivery phases of customers' projects.

For more information on the Rockwell Automation Process System Integrator Program and Solution Provider Program, visit [www.rockwellautomation.com/go/sitj](http://www.rockwellautomation.com/go/sitj).

The tool calculated the predicted network bandwidth, number of connections used and remaining connections available, based on the type and number of nodes on the network.

This information allowed us to determine the network layout and connection media (fiber, copper) most suitable for the project. In

As the system's mechanical design evolved, additional I/O had to be added to support the increased processing capabilities requested by the manufacturer.

addition, it confirmed that the EtherNet/IP network ring had enough bandwidth available to provide the required communications if one of the paths became accidentally disconnected.

The IAB and EtherNet/IP Capacity Tool software tools helped optimize the I/O and network design. However, these tools alone can't determine which design provides the best overall value while still meeting the project's requirements. To do this, we worked with the food manufacturer to evaluate each option's benefits and limitations.

### The Solution Connects Flex/I/O to Ethernet

The project team decided to change the design from ControlNet with rack I/O to an Ethernet system with Allen-Bradley Flex™ I/O (www.

rockwellautomation.com/go/flex\_io) from Rockwell Automation (see **Figure 2**). The deciding factors for the new design were as follows:

- The new design provided a 25% controls hardware cost savings compared to the old design.
- The new design reduced the

## Experts in Dry Solids Feeding Systems and Dynamic Weight-Based Controls

Schenck AccuRate is committed to providing customers best-in-class dry solids metering systems. That's why as proud members of the Rockwell Automation Encompass™ Program, we combine our award-winning feeders, featuring DISOCONT® and INTECONT® modular controllers, with the latest Allen Bradley PLCs, HMI devices and DeviceNet or EtherNet/IP communication products and expertise.

In addition, today our world-renowned MECHATRON® feeders incorporate quality Rockwell products such as terminal blocks, Bulletin 800F switches, and PowerFlex® 4 drives providing the optimal dry solids feeding and dynamic weight-based control solution for your application.



Call us at (800) 558-0184.

[www accuratefeeder.com](http://www accuratefeeder.com)

we make processes work

schenckAccuRate



©2010 Schenck AccuRate

# Paradigm Shift

in Variable Frequency Drive



Harnessing the power of new generation IGBT drives by making better connections

**ServiceDrive**  
Complete ASD/VFD Cable System



800-624-3572 • [servicewire.com](http://servicewire.com)

network types in the plant, thus decreasing training requirements and spare parts needs.

- The new design allowed for additional cost savings during installation because of less expensive Ethernet media run compared to ControlNet.

Every design option typically has drawbacks that the project team needs to accept or find an alternate solution. In this project, the system included safety and other nonsafety I/O connected via DeviceNet. The new design required that the rack-mounted Allen-Bradley 1756-DNB cards, used for connecting to the safety I/O, be replaced with stand-alone Allen-Bradley 1788-EN2DN modules because the field racks were to be eliminated.

For any automation integration project, initial design assumptions made during the early phases should be revised during start of the detailed design.

This was a good solution for the nonsafety I/O. However, the 1788-EN2DN modules aren't rated to connect to safety I/O.

To solve this problem, a CLX rack with a 1756-DNB card was added in each Allen-Bradley CENTERLINE® Motor Control Center (MCC) with IntelliCENTER® ([www.rockwellautomation.com/go/intellicenter](http://www.rockwellautomation.com/go/intellicenter)) for connecting the MCC's drives and starters back to the Allen-Bradley GuardLogix® safety controller ([www.rockwellautomation.com/go/tjguardlogix](http://www.rockwellautomation.com/go/tjguardlogix)).

## Make the Most of a Project

For any automation integration project, initial design assumptions made during the early phases should be revisited during start of detailed design to ensure that the highest-value solution is implemented. Successful collaboration between Polytron and our client to identify the pros and cons of all options helped ensure that the project's requirements were met. □

*Rockwell Automation Solution Provider Polytron, Inc., Duluth, Ga., is a system integrator that provides project management, electrical engineering, automation, manufacturing execution systems and training services for the food, beverage, consumer products and pharmaceutical industries.*

Polytron, Inc.  
[www.rockwellautomation.com/go/p-polytron](http://www.rockwellautomation.com/go/p-polytron)

FREE EXCLUSIVE CONTENT FROM

# THE JOURNAL



You're just 1 click away from getting free online articles from *The Journal*. Just go to [www.rockwellautomation.com/thejournal/go/tjsubscribe](http://www.rockwellautomation.com/thejournal/go/tjsubscribe). Check "The Journal" box to get your free e-newsletter that brings you the digital edition of *The Journal* every issue – plus additional Web-exclusive how-to articles, case studies

and product news from Rockwell Automation and its Encompass Product Partners and Solution Providers.

Visit [www.ROCKWELLAUTOMATION.COM/go/tjsubscribe](http://www.ROCKWELLAUTOMATION.COM/go/tjsubscribe)

**SIGN UP TODAY!**